

# Adaptive Braking Systems (ABS)

National Semiconductor  
System Brief 106  
October 1990

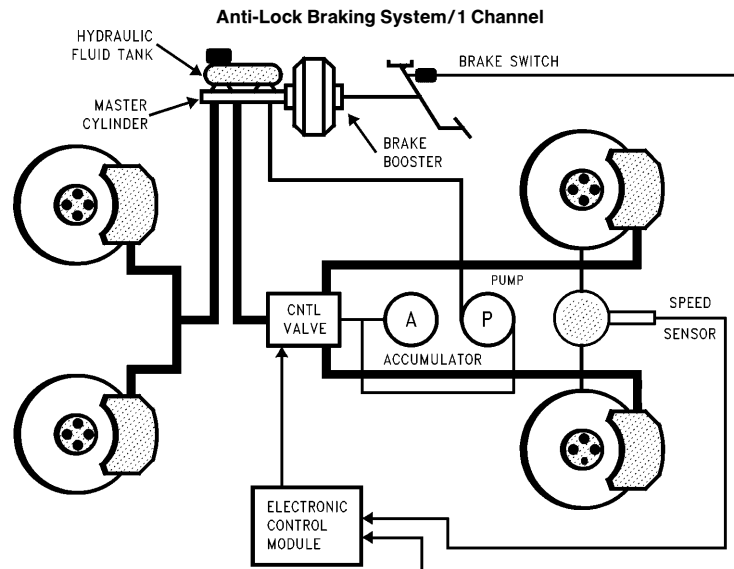

Adaptive Braking Systems (ABS)



## SYSTEM DESCRIPTION

ABS refers to a number of devices designed to avoid wheel-lock during hard and panic braking conditions. These systems have gained world attention only in the past five years, but even the simplest system provides huge gains over electro-mechanical systems. Legislation for ABS continues throughout most of Europe and is expected to be mandated in the U.S. as well.

Four wheel systems provide more security with both steerability and stability, and are second only to engine control in electronic content. ABS systems are designed around system hydraulics, sensors and control electronics. These systems are dependent on each other and the different system components are interchangeable with minor changes in the controller software.

## ANTI-LOCK

Anti-Lock systems are low cost with one wheel sensor on the differential, one control circuit and a system controller

for primarily light truck and front wheel drive passenger cars. This improves stability and only affects the rear wheels.

## ANTI-SKID

Anti-Skid systems provide the next level by adding control to all wheels and includes—three wheel sensors, three control circuits and the system controller. This system provides both steerability and stability during heavy braking, meaning that a driver can maintain full control of the vehicle. This level may soon become law in the U.S.

## ADVANCED ANTI-SKID

This upgrade of the previous system requires four wheel speed sensors, four control circuits, and a high performance control system. This system provides greatly increased control—decreased stopping distances, split surface control (dissimilar road surfaces), and automatic parameter adjustment (to match weather changes). Presently, this system is used only on very high performance vehicles.

SB-106

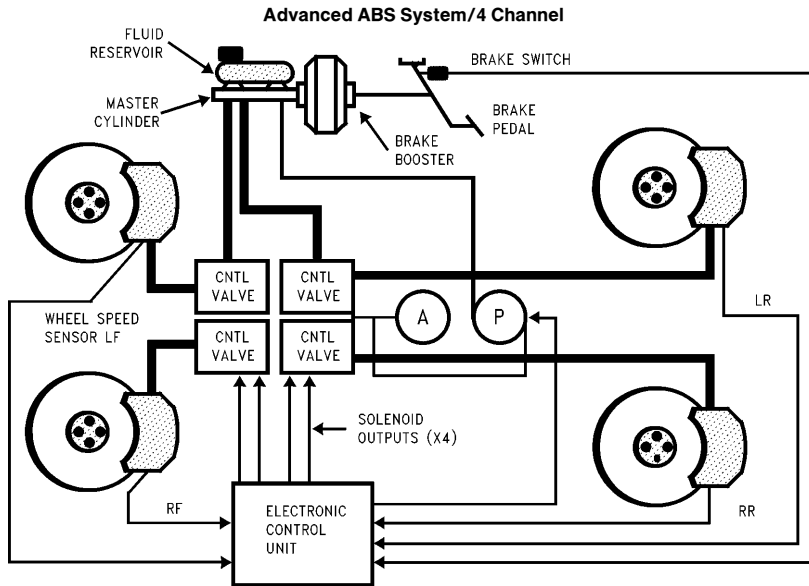

TL/F/10856-2

### TRACTION CONTROL

To control wheel "slip" during acceleration on slippery surfaces, the control system must balance the torque at the driven wheels and the friction from the road and tire surfaces. Two of the most popular methods for controlling torque are engine intervention and brake intervention. These techniques apply the brakes intermittently, where wheel "slip" has been determined, to absorb excess engine torque.

Engine intervention techniques provide some means of controlling torque by either fuel or spark timing adjustments.

### SYSTEM HYDRAULICS

The hydraulic system in the vehicle is augmented by the addition of special hydraulic solenoid switches which allows the control unit to modulate the brake pressure on each of the controlled wheels. The number of wheels controlled depends on the configuration selected by the manufacturer. Typically, an Anti-Lock system has one control circuit which acts on both of the rear wheels, while an Anti-Skid system has three control circuits; one for the two rear wheels and one for each of the two front wheels.

These hydraulic switches allow the brake pressure to be increased, decreased, or held constant during ABS control of the circuit. In the non-operating mode the switches are in the pressure increase position which under normal driving conditions equates to flow through position. Control circuits are either one three-position switch or two two-position switches, again depending on the manufacturer.

Recently, a great deal of attention has been given to the use of Pulse Width Modulated (PWM) pumps which act as

pressure boosters on each of the control lines. This form of control is not only more accurate but avoids many of the traditional problems associated with relatively slow switching solenoids. PWM control will be the next hydraulic system advancement for ABS, both in performance and in cost.

### SYSTEM ELECTRONICS SENSORS

Several different parameters must be checked during normal driving as well as during ABS braking. Possibly, the most important input(s) is that of the speed sensor. In the form of a reluctance sensor, it reads the passing teeth on a gear on the wheel hub. The sensor outputs a sinusoidal wave form which must be changed to a digital wave proportional to wheel speed.

In addition, there are several on/off (digital) inputs which tell the processing unit if the brake pedal has been depressed, if brake fluid is insufficient, and if the parking brake is on.

### PROCESSING

This unit reads the speed sensors to determine both wheel and vehicle speed, and if an ABS event is occurring, and ABS control functions need to be performed. This can include eight solenoids with feed lock loops, continuous self and system diagnosis, service interface, and a display of system status. The substantial control requirements of an advanced ABS system requires a very high performance controller.

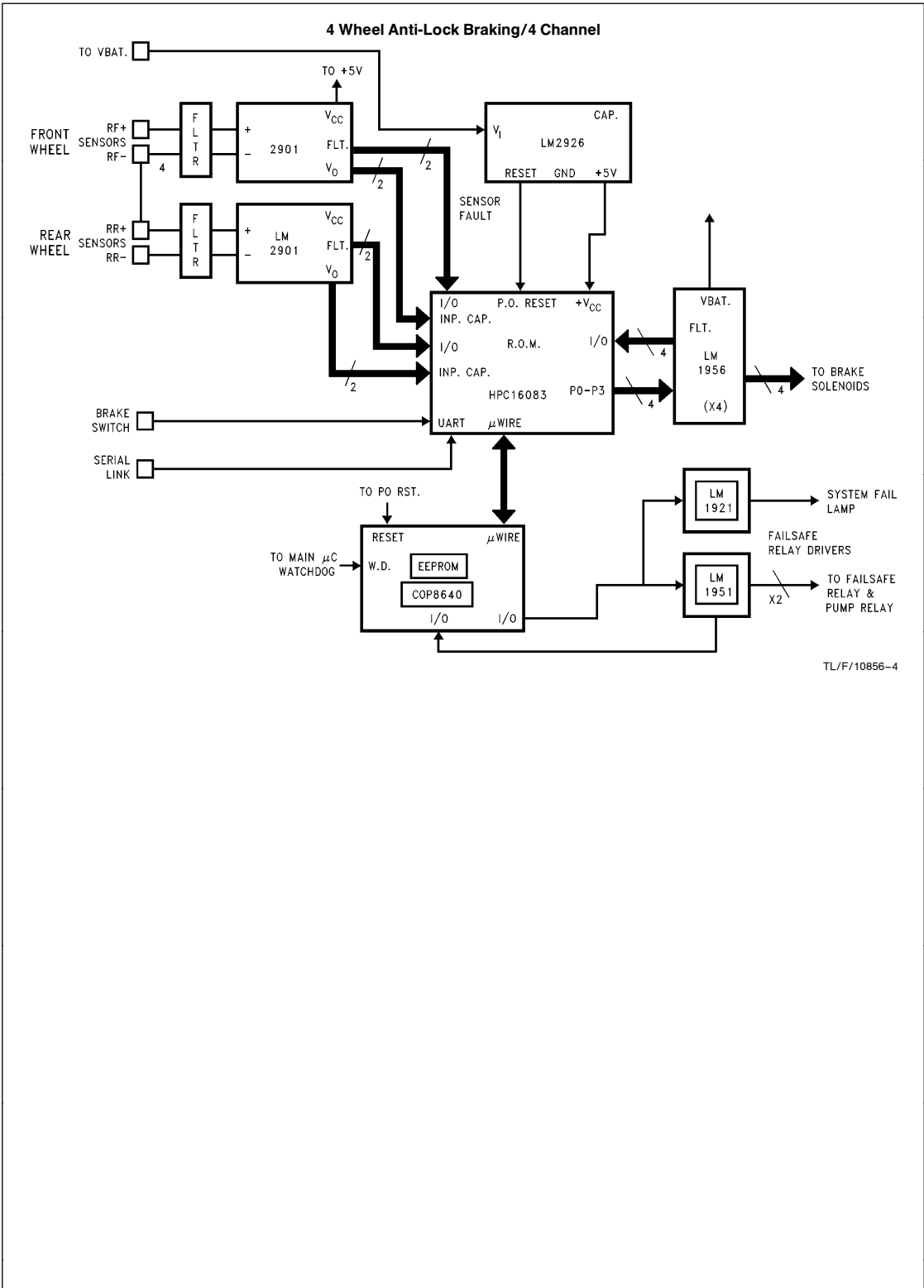

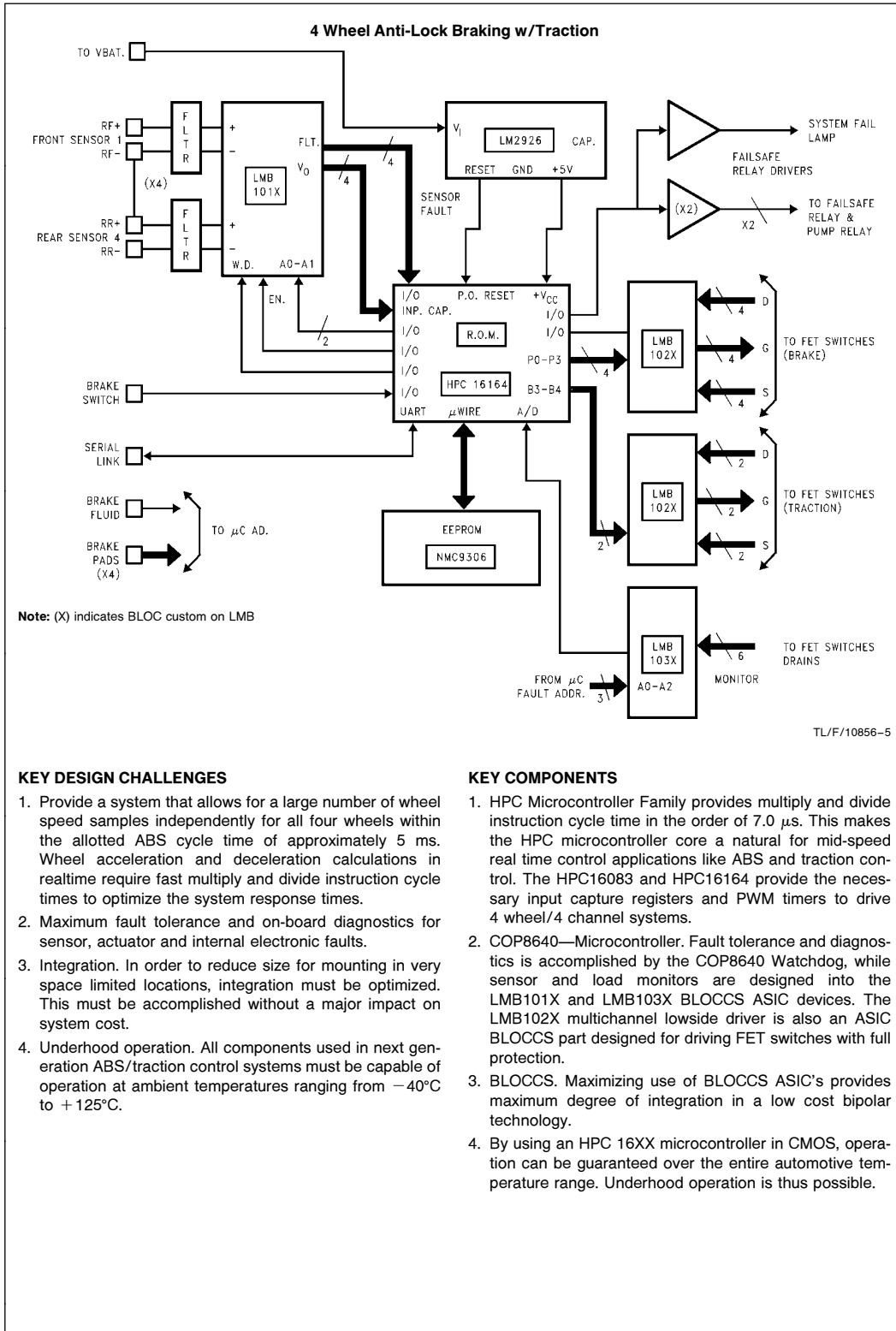

#### KEY DESIGN CHALLENGES

1. Provide a system that allows for a large number of wheel speed samples independently for all four wheels within the allotted ABS cycle time of approximately 5 ms. Wheel acceleration and deceleration calculations in realtime require fast multiply and divide instruction cycle times to optimize the system response times.
2. Maximum fault tolerance and on-board diagnostics for sensor, actuator and internal electronic faults.
3. Integration. In order to reduce size for mounting in very space limited locations, integration must be optimized. This must be accomplished without a major impact on system cost.
4. Underhood operation. All components used in next generation ABS/traction control systems must be capable of operation at ambient temperatures ranging from  $-40^{\circ}\text{C}$  to  $+125^{\circ}\text{C}$ .

#### KEY COMPONENTS

1. HPC Microcontroller Family provides multiply and divide instruction cycle time in the order of  $7.0 \mu\text{s}$ . This makes the HPC microcontroller core a natural for mid-speed real time control applications like ABS and traction control. The HPC16083 and HPC16164 provide the necessary input capture registers and PWM timers to drive 4 wheel/4 channel systems.
2. COP8640—Microcontroller. Fault tolerance and diagnostics is accomplished by the COP8640 Watchdog, while sensor and load monitors are designed into the LMB101X and LMB103X BLOCCS ASIC devices. The LMB102X multichannel lowside driver is also an ASIC BLOCCS part designed for driving FET switches with full protection.
3. BLOCCS. Maximizing use of BLOCCS ASIC's provides maximum degree of integration in a low cost bipolar technology.
4. By using an HPC 16XX microcontroller in CMOS, operation can be guaranteed over the entire automotive temperature range. Underhood operation is thus possible.

**BILL OF MATERIAL**

Function	Description	NSC Part	Other Mfg.	Quantity
<b>4 WHEEL ABS</b>				
CPU/OBROM Microcontroller	16b $\mu$ C	HPC16083		1
Coprocessor Microcontroller w/EEPROM w/Watchdog	8b $\mu$ C	COP8640		1
Sensor Conditioning Comparators	Quad COMP.	LM2901		2
Voltage Regulator V.R.	LDO Reg	LM2926		1
Solenoid Driver Smart Power	5A Highside Driver	*LM1956		4
Lamp Drivers High Side Switch	1A Highside Dr	LM1921		1
Relay Drivers High Side Switch	1A Highside Dr Diagc.	LM1951		1
<b>4 WHEEL ABS/w TRACTION</b>				
CPU Microcontroller	16b Micro w/AD	*HPC16164		1
Sensor Conditioning w/Watchdog w/Sensor Diagnostic	ASIC BLOCCS	LMB101X		1
Odometer EEPROM	EEPROM	NMC9306		1
Voltage Regulator V.R.	LDO Volt Reg	LM2926		1
Solenoid Drivers	ASIC BLOCCS	LMB102X		2
Analog Switch	ASIC BLOCCS	LMB103X		1

\*Preliminary

**LIFE SUPPORT POLICY**

NATIONAL'S PRODUCTS ARE NOT AUTHORIZED FOR USE AS CRITICAL COMPONENTS IN LIFE SUPPORT DEVICES OR SYSTEMS WITHOUT THE EXPRESS WRITTEN APPROVAL OF THE PRESIDENT OF NATIONAL SEMICONDUCTOR CORPORATION. As used herein:

1. Life support devices or systems are devices or systems which, (a) are intended for surgical implant into the body, or (b) support or sustain life, and whose failure to perform, when properly used in accordance with instructions for use provided in the labeling, can be reasonably expected to result in a significant injury to the user.
2. A critical component is any component of a life support device or system whose failure to perform can be reasonably expected to cause the failure of the life support device or system, or to affect its safety or effectiveness.



**National Semiconductor Corporation**  
 1111 West Bardin Road  
 Arlington, TX 76017  
 Tel: 1(800) 272-9959  
 Fax: 1(800) 737-7018

**National Semiconductor Europe**  
 Fax: (+49) 0-180-530 85 86  
 Email: onjwge@tevm2.nsc.com  
 Deutsch Tel: (+49) 0-180-530 85 85  
 English Tel: (+49) 0-180-532 78 32  
 Français Tel: (+49) 0-180-532 93 58  
 Italiano Tel: (+49) 0-180-534 16 80

**National Semiconductor Hong Kong Ltd.**  
 19th Floor, Straight Block,  
 Ocean Centre, 5 Canton Rd.  
 Tsimshatsui, Kowloon  
 Hong Kong  
 Tel: (852) 2737-1600  
 Fax: (852) 2736-9960

**National Semiconductor Japan Ltd.**  
 Tel: 81-043-299-2309  
 Fax: 81-043-299-2408

National does not assume any responsibility for use of any circuitry described, no circuit patent licenses are implied and National reserves the right at any time without notice to change said circuitry and specifications.